

ITEM	PART NO	DESCRIPTION	MATERIAL	PLATING	
①	SBT2.5AA-B	BARREL	BeCu	Au	
②	SBT2.5AA-P	PLUNGER	BeCu	HARDENING Au	
③	SBT2.5AA-S	SPRING	SWP	HARDENING Au	
	SBV2.4AA-PC	JIG PLUNGER	SUS303		
MARK	DESCRIPTION OF REVISION			DATE	NAME
△					

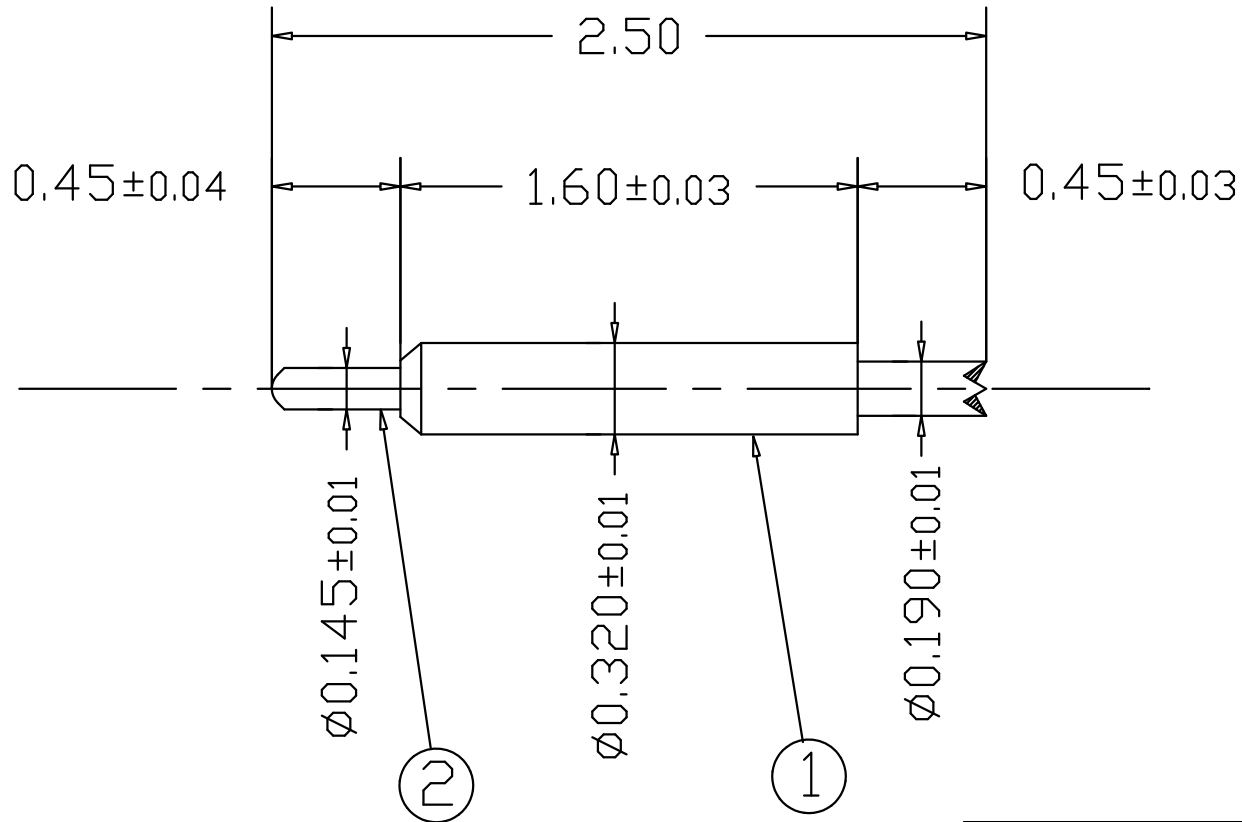

(Note)

- Contact force 34gf@0.3mm (working stroke)
- Max stroke : 0.35mm

DESIGNED	TITLE Assembly Drawing		
CHECKED	SIZE A4	DWG NO. SBT2.5AA	△
APPROVED S.Izumi	SCALE	Link-MicRo' Co.,Ltd.	
DRAWN 2005.08.08			