

| ITEM | PART NO                 | DESCRIPTION | MATERIAL | PLATING      |      |
|------|-------------------------|-------------|----------|--------------|------|
| ①    | LFV2.18AA-B             | BARREL      | BeCu     | Silvaco      |      |
| ②    | SBT2.5AA-P              | PLUNGER     | BeCu     | HARDENING Au |      |
| ③    | SBT2.5AA-S              | SPRING      | SWP H/T  | HARDENING Au |      |
|      |                         |             |          |              |      |
|      |                         |             |          |              |      |
| MARK | DESCRIPTION OF REVISION |             |          | DATE         | NAME |
| △    |                         |             |          |              |      |

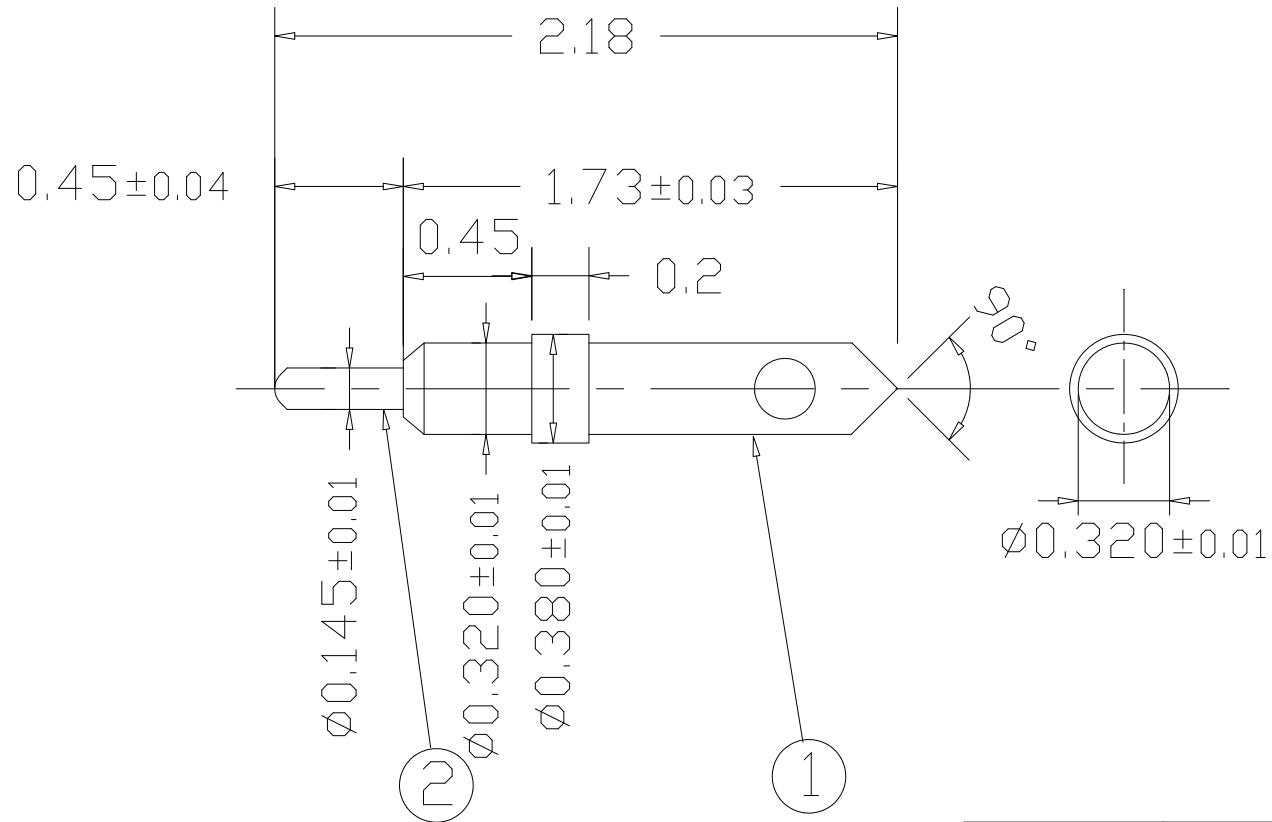

(Note)

- Contact force 34gf@0.3mm (working stroke)
- Max stroke : 0.35mm

|                     |                           |                       |   |
|---------------------|---------------------------|-----------------------|---|
| DESIGNED            | TITLE<br>Assembly Drawing |                       |   |
| CHECKED             | SIZE<br>A4                | DWG NO.<br>LFV2.18AAH | △ |
| APPROVED<br>S.Izumi | SCALE                     | Link-MicRo' Co.,Ltd.  |   |
| DRAWN<br>2005.12.02 |                           |                       |   |