

ITEM	PART NO	DESCRIPTION	MATERIAL	PLATING	
①	CST4.9BB-B	BARREL	PBT	Au	
②	CST5.8AA-PA	PLUNGER A	BeCu	HARDENING Au	
③	CST5.8AA-PB	PLUNGER B	BeCu	HARDENING Au	
④	CST5.8AA-S	SPRING	SWP	Au	
MARK	DESCRIPTION OF REVISION			DATE	NAME
△					

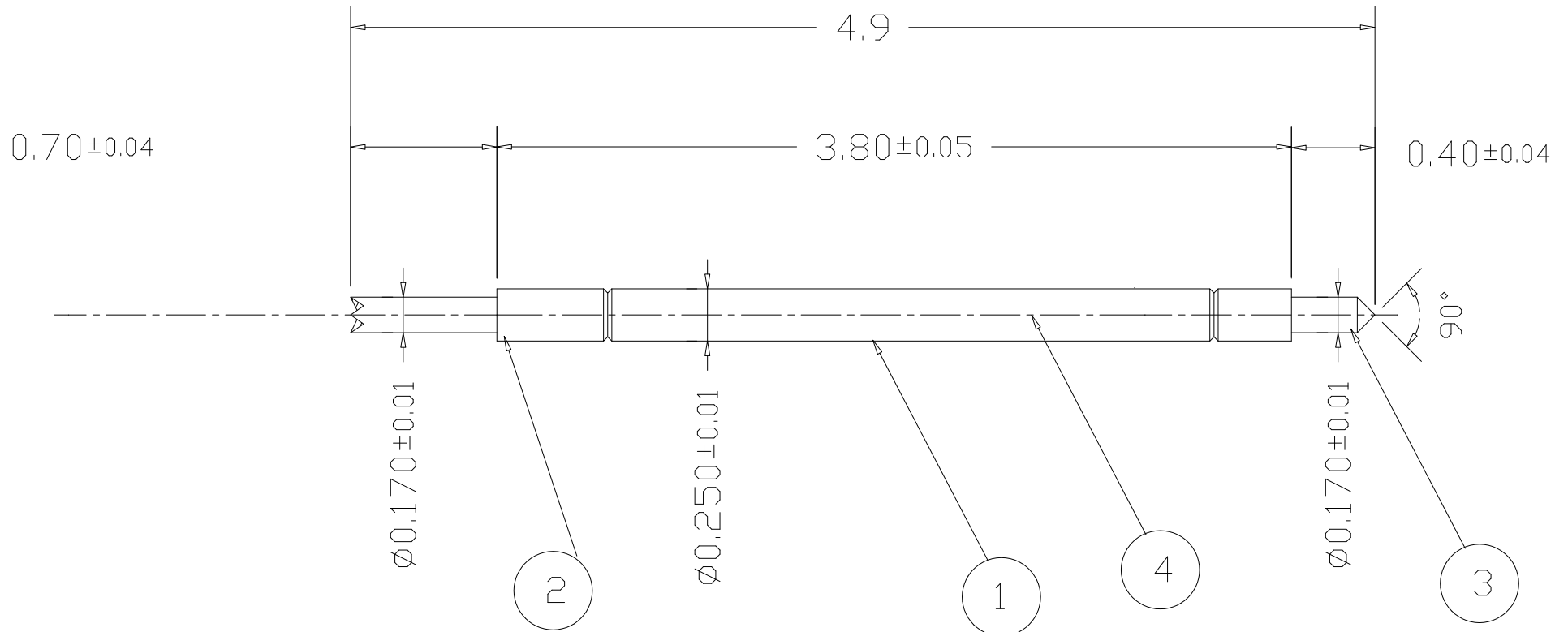

(Note)

- Working Travel : 0.4mm (Max 0.5)
Application side; 0.25mmST Board side; 0.15mmST
- Spring force : 25gf ± 6gf (@working travel)

DESIGNED Yoshida	TITLE ASSEMBLY DRAWING		
CHECKED	SIZE A4	DWG NO. CST4.9BB	△
APPROVED S.Izumi	SCALE	Link-MicRo' CO., LTD.	
DRAWN 2004.11.12.			