

ITEM	PART NO	DESCRIPTION	MATERIAL	PLATING	
①	CSR6.0CC-PA	PLUNGER A	SK-4	Au	
②	CSR6.0CC-PB	PLUNGER B	SK-4	Au	
③	CSR6.0BB-B	BARREL<Seamless>	AUPB		
④	CSR6.0CC-S	SPRING	SWP	Au	
MARK	DESCRIPTION OF REVISION			DATE	NAME
△					

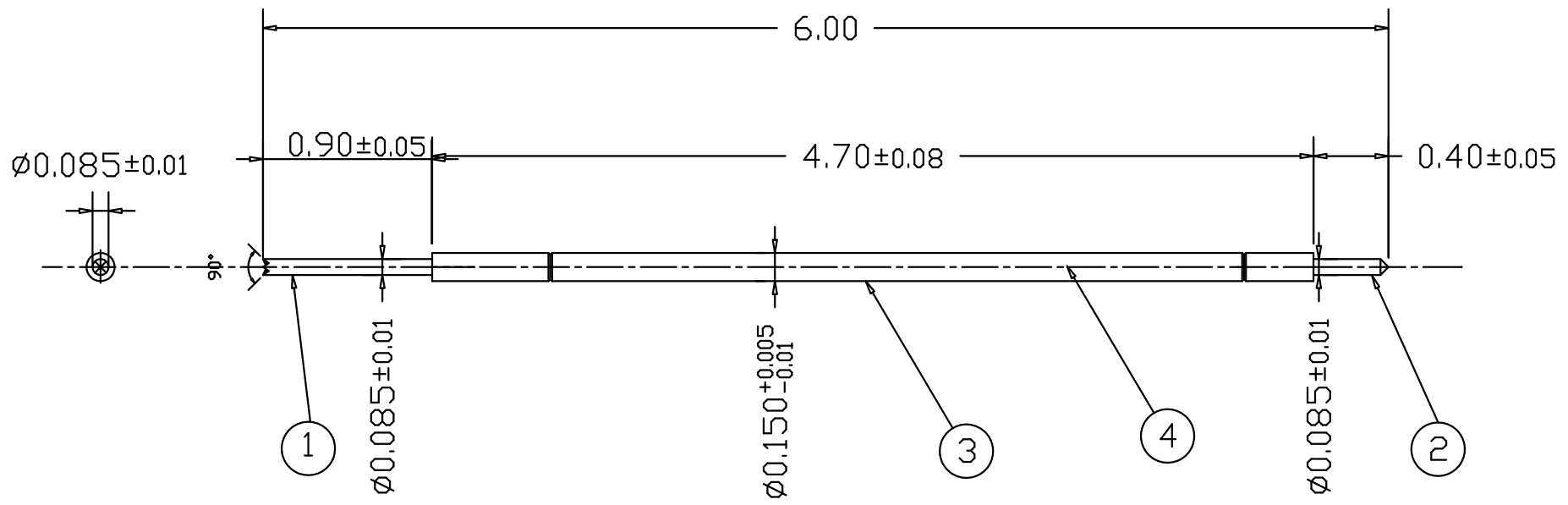

(Note)

1. Spring Force ; 8.0gf ± 10% @ 0.5mm, working travel
2. Max stroke ; 0.6mm

DESIGNED Yoshida	TITLE ASSEMBLY DRAWING		
CHECKED	SIZE A4	DWG NO. CSR6.0CC	△
APPROVED IZUMI	SCALE	Link-MicRo' Co.,Ltd..	
DRAWN 2006.02.18			