

ITEM	PART NO	DESCRIPTION	MATERIAL	PLATING
①	CSQ3.3AB-B	BARREL	electroformed pipe	-
②	CSQ3.3AB-PA	PLUNGER A	SP-1	-
③	CSQ3.3AB-PB	PLUNGER B	SK	HARDENING Au
④	CSQ3.3AB-SP	SPRING	SWP H/T	Au
MARK	DESCRIPTION OF REVISION		DATE	NAME

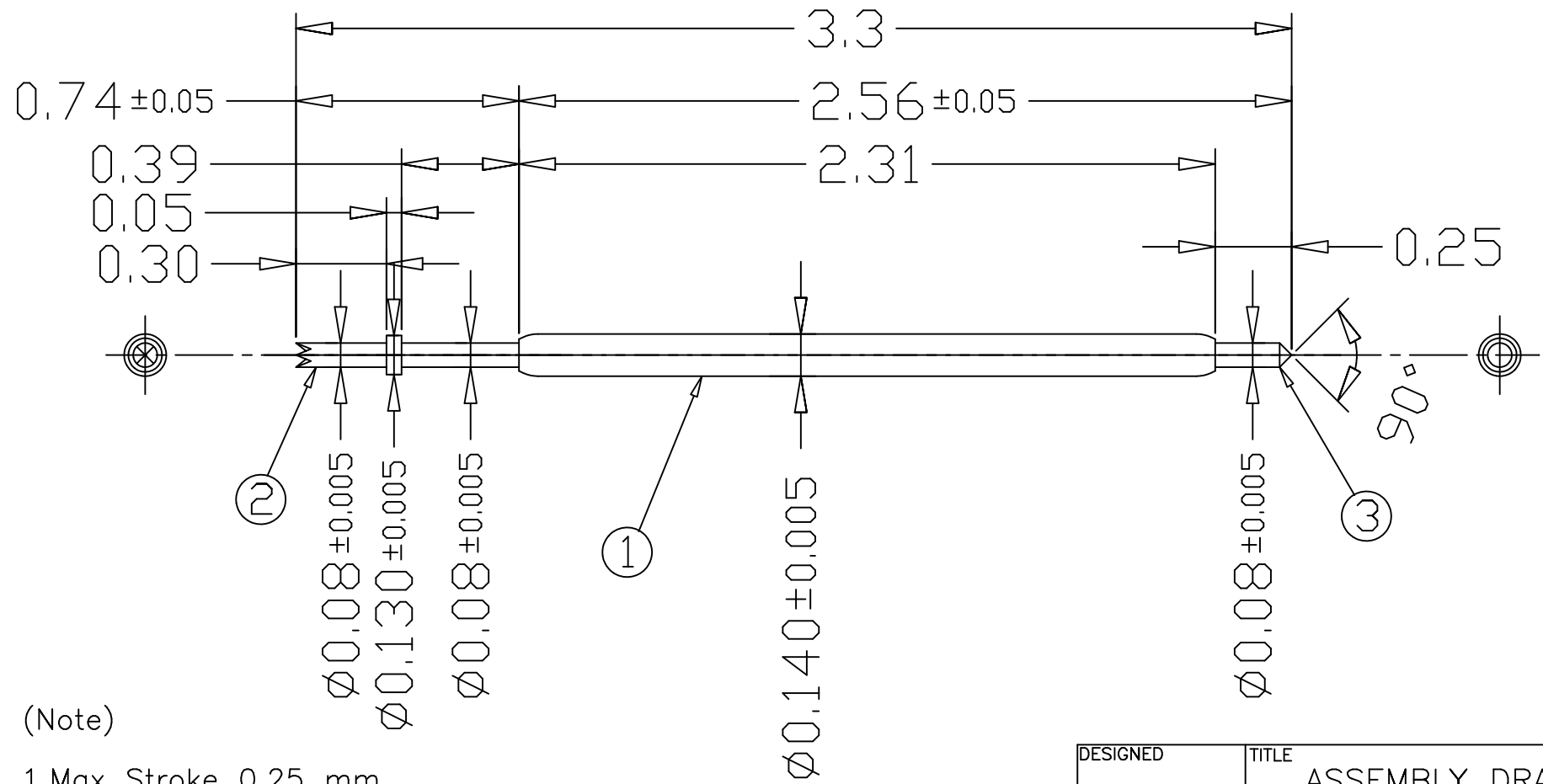

- (Note)
- 1.Max Stroke 0.25 mm
 - 2.Recommended Contact force : 12gf at 0.20 mm. stroke
 - 3.Cutter angle PA : 60°

DESIGNED	TITLE		
CHECKED	ASSEMBLY DRAWING		
APPROVED	SIZE	DWG NO.	△
S.Izumi	A4	CSQ3.3AB	
DRAWN	SCALE	Link-MicRo' Co.,Ltd..	
2007.10.12			